



## Steca Tarom

235, 245, 440

The Steca Tarom is a solar charge controller specifically designed for use in telecommunications applications or in hybrid photovoltaic systems.

Numerous clever functions allow the user to adjust the controller to the particular features of the system in question. Thanks to the significantly improved state of charge determination, the system is optimally controlled and batteries are protected. The Steca Tarom charge controller is the best choice for system sizes of up to 2400 Wp at three voltage levels (12 V, 24 V, 48 V).

There is the option of connecting additional devices such as a temperature sensor, a data logger and a remote control for configuring and monitoring the system. An integrated Ah meter also provides the user with information on the energy budget of the application.



### Product features

- Hybrid controller
- State of charge determination with Steca AtonIC (SOC)
- Automatic detection of voltage
- PWM control
- Multistage charging technology
- Load disconnection depending on SOC
- Automatic load reconnection
- Temperature compensation
- Common positive grounding or negative grounding on one terminal
- Integrated data logger
- Night light function with Steca PA 15
- Integrated self test
- Monthly maintenance charge
- Integrated energy meter

### Electronic protection functions

- Overcharge protection
- Deep discharge protection
- Reverse polarity protection of load and module
- Reverse polarity protection by internal fuse
- Automatic electronic fuse
- Short circuit protection of load and module
- Overvoltage protection at module input
- Open circuit protection without battery
- Reverse current protection at night
- Overtemperature and overload protection
- Battery overvoltage shutdown

### Displays

- Text LCD display  
— for operating parameters, fault messages, self test

### Operation

- Simple menu-driven operation
- Programming by buttons
- Manual load switch

### Interfaces

- RJ45 interface

### Options

- External temperature sensor
- Alarm contact

### Certificates

- Approved by the World Bank for Nepal
- Compliant with European Standards (CE)
- Made in Germany
- Developed in Germany
- Manufactured according to ISO 9001 and ISO 14001

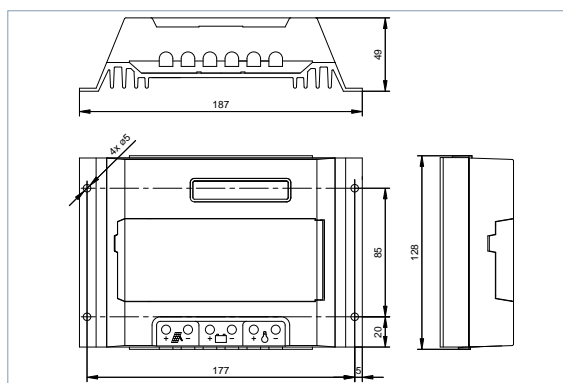
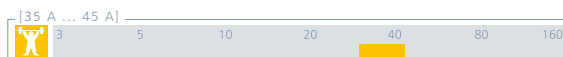

	235	245	440
<b>Characterisation of the operating performance</b>			
System voltage	12 V (24 V)		48 V
Own consumption	14 mA		
<b>DC input side</b>			
Open circuit voltage solar module	< 47 V		< 82 V
Module current	35 A	45 A	40 A
<b>DC output side</b>			
Load current	35 A	45 A	40 A
End of charge voltage	13.7 V (27.4 V)	54.8 V	
Boost charge voltage	14.4 V (28.8 V)	57.6 V	
Equalisation charge	14.7 V (29.4 V)	58.8 V	
Reconnection voltage (SOC / LVR)	> 50 % / 12.6 V (25.2 V)	> 50 % / 50.4 V	
Deep discharge protection (SOC / LVD)	< 30 % / 11.1 V (22.2 V)	< 30 % / 44.4 V	
<b>Operating conditions</b>			
Ambient temperature	-10 °C ... +60 °C		
<b>Fitting and construction</b>			
Terminal (fine / single wire)	16 mm <sup>2</sup> / 25 mm <sup>2</sup> - AWG 6 / 4		
Degree of protection	IP 32		
Dimensions (X x Y x Z)	187 x 128 x 49 mm		
Weight	550 g		

programmable

Technical data at 25 °C / 77 °F



**Steca PA Tarcom**  
Data logger



**Steca PA HS200**  
Shunt



**Steca PA 15**  
Remote control

[areas of application]

